

Task Specific

Sorting Center 12" Wide High Bay

U12M

PATENT PENDING

Product Description

A high efficiency fluorescent high-bay that provides exceptional light distribution for general areas in a 12" wide profile housing. Modified fixture and reflector design provides optimal light distribution for sorting centers, conveyor systems, loading and unloading trailers. Available with full 10 gauge wireguard safety option. Reflector integrity protected by full housing surround.

U12M fixtures offer flexible mounting methods that include standard chain hangers, surface mounting or optional mounting features for 3/4" pendant mounting.

Hanging Options Include:

- Surface Mount [Mounting holes provided in the housing]
- Chain Mount [Chain hangers are supplied with the fixture]
- Quick Cable [QC – Optional quick hang cable system]
- Junction Box [JB – Optional slide-on splice box for 3/4" stem]
- Pendant Stabilizer [PS – Optional Bracket for stabilizing fixture when single point hanging with a 3/4" stem]
- Hook [SPSH – 12" stem, pendant stabilizer & hook for hanging in loop or eye-bolt]
- Quick Toggle [SPSQ – 12" Stem, pendant stabilizer & quick toggle]

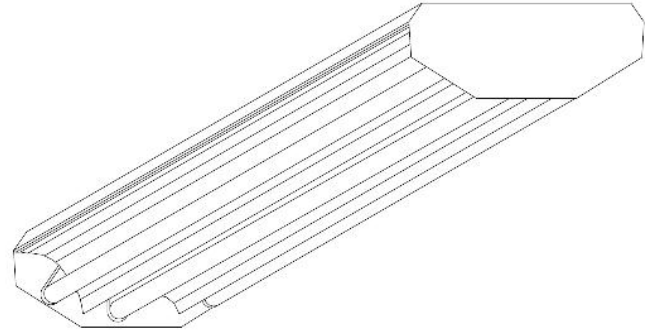

General Construction

The U12M fixture housing is brake formed from heavy gauge cold rolled steel. Ends and socket plates are permanently riveted together for strength and rigidity. The housing is post painted with durable, highly reflective powder-coat finish.

The optical reflector system is precision brake formed of the selected aluminum material. The one piece reflector is removable without the use of tools, using 1/4 turn fasteners to secure it in place.

Polycarbonate rotary style locking lampholders are utilized to ensure positive lamp retention and long life in high temperature applications.

All fixtures utilize U.L approved components, are U.L approved and will bear U.L labels.

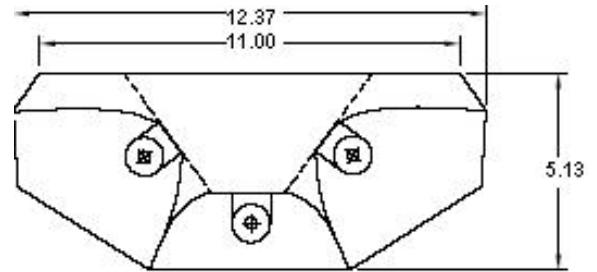

FIXTURE ORDERING INFORMATION

FIXTURE SERIES	#LAMPS	LAMP TYPE	VOLTAGE	#BALLASTS	BALLAST TYPE	REFLECTOR	HANGING	OPTIONS	LAMP COLOR
U12M	4	32	12	2	HI	E	QC	OS	835
	5	54	27	3	LI	A	JB	WG	841
	6		34	4	SI	W	PS	E (#)	850
			UV		PS		SPSH	F	865
			HV		PD		SPSQ	SC	
								NYC	

Lamp Type Selections:

- 32 – F32T8 System
- 54 – F54T5HO System

Voltage Selections:

- 12 – 120V
- 27 – 277V
- 34 – 347V
- UV – 120-277V
- HV – 347-480V (T5HO Only)

Ballast Selections:

- HI – High BF Electronic Instant Start
- LI – Low BF Electronic Instant Start
- SI – Standard BF Electronic Instant Start
- PS – Programmed Start Electronic
- PD – Programmed Start Dimming

Reflector Selections:

- E – Enhanced Aluminum
- A – Polished Aluminum
- W – Highly Reflective White

Hanging Selections:

- QC – Quick Hang Cables (5ft)
- JB – Slide-on Junction Box
- PS – Pendant Stabilizer
- SPSH – 12" Stem/PS/Hook
- SPSQ – 12" Stem/PS/Quick Toggle

Option Selections:

- OS – Occupancy Sensor
- WG – Wire Guard
- E () – Emergency Pack (Specify # of required Lumens)
- SC – Safety Cable
- C () – 16/3 Cord (Specify length)
- TL () – Locking Cord End (Specify Nema Configuration)
- NYC – NYC Approved 20-Gauge



Phone: 1-800-541-9082
 Fax: 1-888-214-7667
 Web: www.optimumlighting.com

TYPE :

CAT# :

PROJECT :